



Description

SE9013 is a complete constant-current & constant voltage linear charger for single cell NiMH or others around 1.5V to 4.2V rechargeable batteries. Its SOT-23-6 package and low external component count make SE9013 ideally suited for portable applications. Furthermore, the SE9013 is specifically designed to work within USB power specification.

No external sense resistor is needed, and no blocking diode is required due to the internal MOSFET architecture. Thermal feedback regulates the charge current to limit the die temperature during high power operation or high ambient temperature. The SE9013 automatically terminates the charge cycle when the charge current drops to 1/5th the programmed value after the final float voltage is reached.

When the input supply (wall adapter or USB supply) is removed, the SE9013 automatically enters a low current stage, dropping the battery drain current to less than 20uA. The SE9013 can be put into shutdown mode, reducing the supply current to 9uA.

Other features include charge current monitor, undervoltage lockout, automatic recharge and a status pin to indicate charge termination and the presence of an input voltage. SE9013 is intentionally designed to have slightly negative Tempco.

Features

- Programmable Charge Current Up to 500mA.
- No MOSFET, Sense Resistor or Blocking Diode Required.
- Constant-Current/Constant-Voltage Operation with Thermal Protection to Maximize Charge Rate without Risk of Overheating.
- Charges Single Cell Li-Ion Batteries Directly from USB Port.
- Programmable Charge of 1.4-4.2V Voltage with $\pm 1.5\%$ Accuracy.
- 9uA Supply Current in Shutdown.
- Soft-Start Limits Inrush Current.
- Available in 6-Lead SOT-23 and PSOP-8 (Exposed Pad) Packages.
- RoHS Compliant and 100% Lead (Pb)-Free

Application

- Cellular Telephones, PDA's, MP3 Players.
- Charging Docks and Cradles
- Bluetooth Applications

Pin Configuration

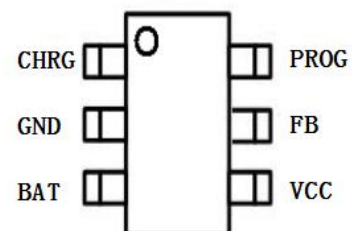



Application Diagram

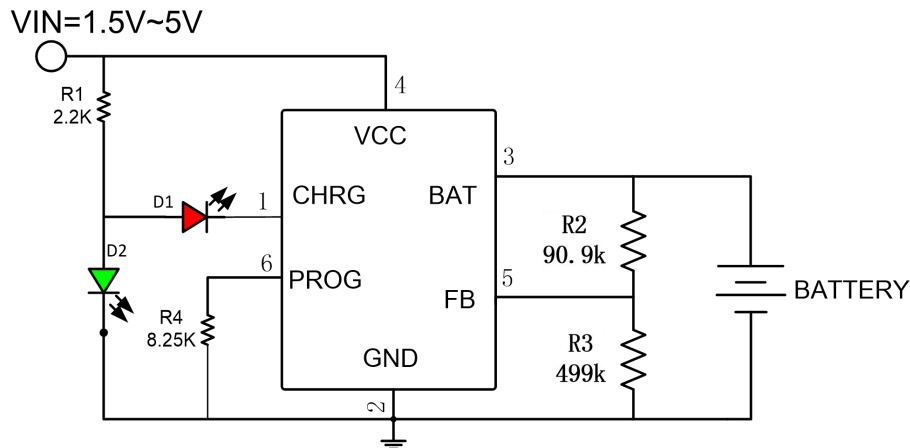

Absolute Maximum Rating ⁽¹⁾

Parameter	Symbol	Value	Units
Input Supply Voltage	V _{CC}	7	V
PROG Voltage	V _{PROG}	V _{CC} +0.3	V
BAT Voltage	V _{BAT}	7	V
CHRG Voltage	V _{CHRG}	7	V
BAT Short-Circuit Duration		Continuous	
Thermal Resistance, Junction-to-Ambient	θ _{JA}	250 (SOT-23-6)	°C/W
		75(PSOP8)	
BAT Pin Current	I _{BAT}	500	mA
PROG Pin Current	I _{PROG}	500	μA
Maximum Junction Temperature	T _J	125	°C
Storage Temperature	T _S	-65 to +125	°C
Lead Temperature (Soldering, 10 sec)		300	°C

Operating Rating ⁽²⁾

Parameter	Symbol	Value	Units
Supply Input Voltage	V _{IN}	-0.3 to +7	V
Junction Temperature	T _J	-40 to +85	°C



Electrical Characteristics

$V_{IN} = 5V$; $T_J = 25^{\circ}C$; $R_2=10K$, $R_3=51K$, unless otherwise specified.

Symbol	Parameter	Conditions	Min	Typ	Max	Unit
V_{CC}	Input Supply Voltage		3.5		6	V
I_{CC}	Input Supply Current	Charge Mode ⁽³⁾ , $R_{PROG} = 2k$		614		μA
		Standby Mode (Charge Terminated)		83		μA
		Shutdown Mode(R_{PROG} Not Connected, $V_{CC} < V_{BAT}$, or $V_{CC} < V_{UV}$)		470		μA
V_{FB}	Feedback Voltage	$I_{BAT} = 300mA$		1.200		V
I_{BAT}	BAT Pin Current	$R_{PROG} = 10k$, Current Mode		107		mA
		$R_{PROG} = 2k$, Current Mode		530		mA
		Standby Mode, $V_{BAT} = 1.42V$		12.36		μA
		Shutdown Mode (R_{PROG} Not Connected)		9.92		μA
		Sleep Mode, $V_{CC} = 0V$		26.6		μA
V_{FLOAT}	Regulated Output (Float) Voltage	$I_{BAT} = 80mA$, $I_{CHRG} = 5mA$		1.425		V
V_{UV}	V_{CC} Undervoltage Lockout Threshold	From V_{CC} Low to High		1.125		V
V_{UVHYS}	V_{CC} Undervoltage Lockout Hysteresis			89		mV
V_{MSD}	Manual Shutdown Threshold Voltage	PROG Pin Rising		1.165		V
		PROG Pin Falling		1.125		V
V_{ASD}	$V_{CC} - V_{BAT}$ Lockout Threshold Voltage	V_{CC} from Low to High		125		mV
		V_{CC} from High to Low		35		mV
T_{LIM}	Thermal Protection Temperature			136		$^{\circ}C$
I_{PROG}	PROG Pin Pull-Up Current			0.782		μA

Note 1: Exceeding the absolute maximum rating may damage the device.

Note 2: The device is not guaranteed to function outside its operating rating.

Note 3: Supply current includes PROG pin current (approximately 100 μA) but does not include any current delivered to the battery through the BAT pin (approximately 100mA).

Note 4: I_{TERM} is expressed as a fraction of measured full charge current with indicated PROG resistor.



Pin Functions

Pin	Pin Function Description	Pin	Pin Function Description
VCC	Positive Input Supply Voltage. Provides power to the charger. VCC can range from 3.5 to 6.5V and should be bypassed with at least a 1 μ F capacitor.	CHRG	The CHRG pin can be used to drive LED's, During charging, it is driven High to turn n Red LED. When the charging is finished, it is driven Low to turn on Green LED.
GND	Ground.	PROG	Charge Current Program, Charge Current Monitor and Shutdown Pin.
BAT	Charge Current Output. Provides charge current to the battery and regulates the final float voltage to 1.4~4.2V.	Vfb	Voltage Feedback to SE9013. It is internally referenced to 1.20V. The programmable Vbat is 1.4 to 4.2V.



Operation

The SE9013 is a single cell NiMH battery charger using a constant-current/constant-voltage algorithm. It can deliver up to 500mA of charge current (using a good thermal PCB layout) with a final float voltage accuracy of $\pm 1\%$. The SE9013 includes an internal P-channel power MOSFET and thermal regulation circuitry. No blocking diode or external current sense resistor is required; thus, the basic charger circuit requires only two external components. Furthermore, the SE9013 is capable of operating from a USB power source.

Normal Charge Cycle

A charge cycle begins when the voltage at the VCC pin rises above the UVLO threshold level and a 1% program resistor is connected from the PROG pin to ground or when a battery is connected to the charger output.

When the BAT pin approaches the final float voltage (1.4~4.2V depending on the customer setup), the SE9013 enters constant-voltage mode and the charge current begins to decrease. When the charge current drops to 60% of the programmed value, the charge cycle ends.

Programming Battery Charge Voltage

The final voltage the battery is to be charged to is determined by the following equation:

$$V_{BAT} = \frac{V_{FB}}{R3} \times (R2 + R3)$$

Where V_{FB} is typically at 1.20V.

Programming Charge Current

The charge current is programmed using a single resistor from the PROG pin to ground. The battery charge current is 1060 times the current out of the PROG pin. The program resistor and the charge

current are calculated using the following equations:

$$R_{PROG} = \frac{1060V}{I_{CHG}}, I_{CHG} = \frac{1060V}{R_{PROG}}$$

The charge current out of the BAT pin can be determined at any time by monitoring the PROG pin voltage using the following equation:

$$I_{BAT} = \frac{V_{PROG}}{R_{PROG}} \cdot 1060$$

This actual current will vary from IC to IC. The typical variation is within $\pm 20\%$.

Charge Termination

A charge cycle is terminated when the charge current falls to 1/5th the programmed value after the final float voltage is reached. This condition is detected by using an internal, filtered comparator to monitor the PROG pin. When the PROG pin voltage falls below 100mV for longer than t_{TERM} (typically 1ms), charging is terminated. The charge current is latched off and the SE9013 enters standby mode, where the input supply current drops to 200mA.

When charging, transient loads on the BAT pin can cause the PROG pin to fall below 100mV for short periods of time before the DC charge current has dropped to 1/5th the programmed value. The 1ms filter time (t_{TERM}) on the termination comparator ensures that transient loads of this nature do not result in premature charge cycle termination. Once the average charge current drops below 1/5th the programmed value, the SE9013 terminates the charge cycle and ceases to provide any current through the BAT pin. In this state, all loads on the BAT pin must be supplied by the battery.

The SE9013 constantly monitors the BAT pin voltage



Charge Status Indicator

CHRG Pin can be connected to Green and Red LED's at the same time. During charging, the CHRG is driven high to turn on Red LED with about 10mA current. When the charging is finished, the CHRG pin is driven low to turn on Green LED. The typical current to turn on Green or Red LEDs is 10mA. If smaller current is desired, a 1-3K resistor can be placed in series with the LED's.

Thermal Limiting

An internal thermal feedback loop reduces the programmed charge current if the die temperature attempts to rise above a preset value of approximately 120°C. This feature protects the SE9013 from excessive temperature and allows the user to push the limits of the power handling capability of a given circuit board without risk of damaging the SE9013. The charge current can be set according to typical (not worst-case) ambient temperature with the assurance that the charger will automatically reduce the current in worst-case conditions.

Undervoltage Lockout (UVLO)

An internal undervoltage lockout circuit monitors the input voltage and keeps the charger in shutdown mode until VCC rises above the undervoltage lockout threshold. The UVLO circuit has a built-in hysteresis of 200mV. Furthermore, to protect against reverse current in the power MOSFET, the UVLO circuit keeps the charger in shutdown mode if VCC falls to within 30mV of the battery voltage. If the UVLO comparator is tripped, the charger will not come out of shutdown mode until VCC rises 100mV above the battery voltage.



Application Hints

Stability Considerations

The constant-voltage mode feedback loop is stable without an output capacitor provided a battery is connected to the charger output. With no battery present, an output capacitor is recommended to reduce ripple voltage. When using high value, low ESR ceramic capacitors, it is recommended to add a 1Ω resistor in series with the capacitor. No series resistor is needed if tantalum capacitors are used.

In constant-current mode, the PROG pin is in the feedback loop, not the battery. The constant-current mode stability is affected by the impedance at the PROG pin. With no additional capacitance on the PROG pin, the charger is stable with program resistor values as high as 20k. However, additional capacitance on this node reduces the maximum allowed program resistor. The pole frequency at the PROG pin should be kept above 100kHz.

V_{CC} Bypass Capacitor

Many types of capacitors can be used for input bypassing, however, caution must be exercised when using multilayer ceramic capacitors. Because of the self-resonant and high Q characteristics of some types of ceramic capacitors, high voltage transients can be generated under some start-up conditions, such as connecting the charger input to a live power source. Adding a 1.5Ω resistor in series with a ceramic capacitor will minimize start-up voltage transients.

Power Dissipation

The conditions that cause the SE9017 to reduce charge current through thermal feedback can be approximated by considering the power dissipated in the IC. Nearly all of this power dissipation is generated by the internal MOSFET—this is calculated to be approximately:

$$P_D = (V_{CC} - V_{BAT}) \cdot I_{BAT}$$

The approximate ambient temperature at which the thermal feedback begins to protect the IC is:

$$T_A = 120^\circ\text{C} - P_D \theta_{JA}$$

$$T_A = 120^\circ\text{C} - (V_{CC} - V_{BAT}) \cdot I_{BAT} \cdot \theta_{JA}$$

Thermal Considerations

Because of the small size of the thin SOT23 package, it is very important to use a good thermal PC board layout to maximize the available charge current. The thermal path for the heat generated by the IC is from the die to the copper lead frame, through the package leads, (especially the ground lead) to the PC board copper. The PC board copper is the heat sink. The footprint copper pads should be as wide as possible and expand out to larger copper areas to spread and dissipate the heat to the surrounding ambient. Other heat sources on the board, not related to the charger, must also be considered when designing a PC board layout because they will affect overall temperature rise and the maximum charge current.



Applications

No-load indications

Put a 10uF capacitor between BAT and GND .
This makes up of a No-load indications circuit as shown below. If there is no battery connected to BAT and GND of SE9013 then we can see that LED-R will be flashing at 2.5 Hz/S. If there is a battery connected to BAT and GND Pin of SE9013. Than SE9013 enters normal charging cycle.

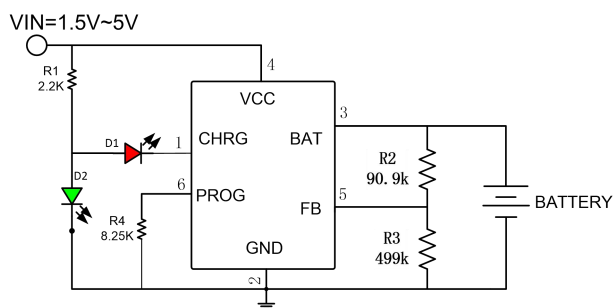



PCBLAYOUT 示意图

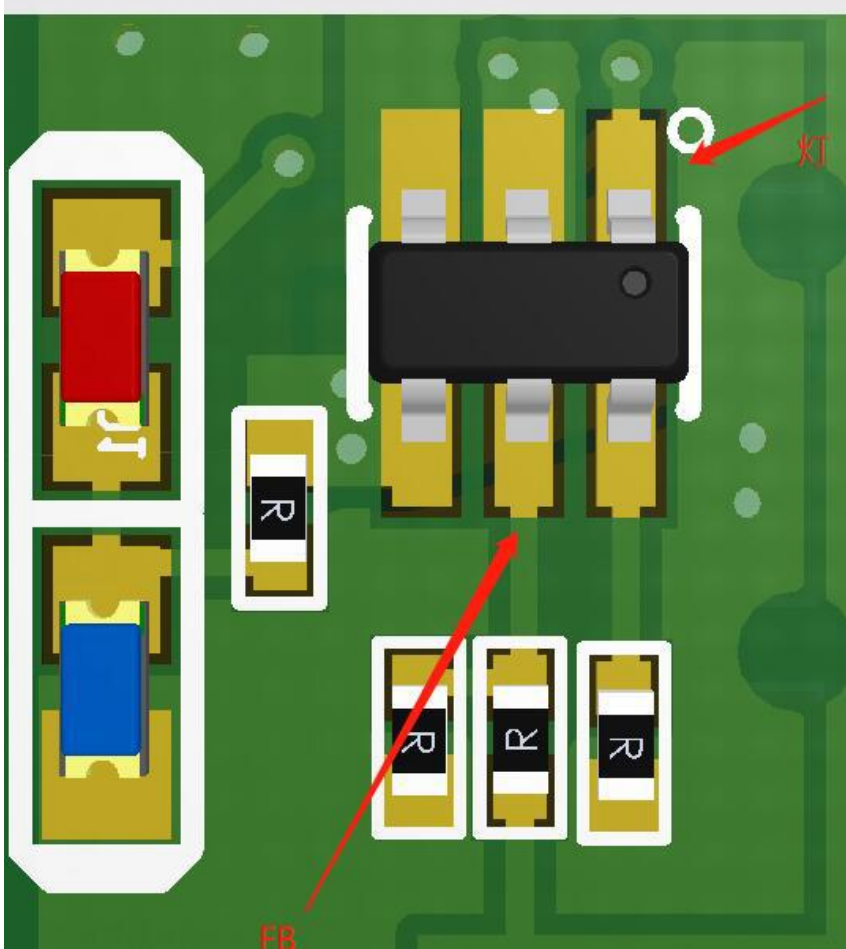

Please note that LED pin carries strong digital signal and FB pin is the high impedance pin. We intentionally separated these two pins on two sides of the package. It is important to continue placing the related PCB traces on both sides of the PCB so that the LED digital signal will not interfere with the FB pin during the LED transition period. If it is necessary to place them close to each other, please add a GND trace to provide a ground loop for better isolation.

请注意我们是有意把 FB 脚位与 LED 脚位放在芯片的两侧，以避免或减少 LED 对 FB 的干扰。请继续把与 LED 和 FB 有关的 PCB 布线分开在芯片两侧以避免转灯的干扰。如果一定要把 FB 与 LED 放在靠近的位置，请用 GND 把两条线隔离开。



OUTLINE DRAWING SOT-23-6L

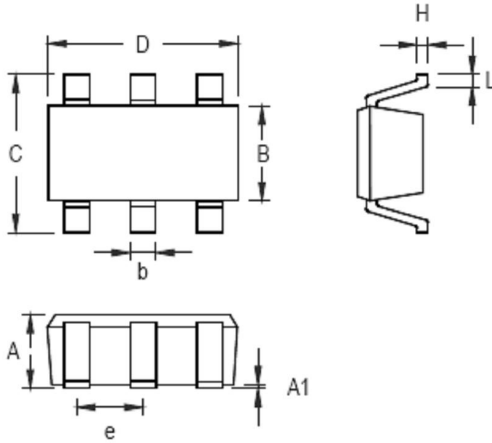

Symbol	Dimensions In Millimeters		Dimensions In Inches	
	Min	Max	Min	Max
A	0.889	1.295	0.031	0.051
A1	0.000	0.152	0.000	0.006
B	1.397	1.803	0.055	0.071
b	0.250	0.560	0.010	0.022
C	2.591	2.997	0.102	0.118
D	2.692	3.099	0.106	0.122
e	0.838	1.041	0.033	0.041
H	0.080	0.254	0.003	0.010
L	0.300	0.610	0.012	0.024



Customer Support

Seaward Electronics Incorporated – China

Section B, 2nd Floor, ShangDi Scientific Office Complex, #22 XinXi Road

Haidian District, Beijing 100085, China

Tel: 86-10-8289-5700/01/05

Fax: 86-10-8289-5706

Seaward Electronics Corporation – Taiwan

2F, #181, Sec. 3, Minquan East Rd,

Taipei, Taiwan R.O.C

Tel: 886-2-2712-0307

Fax: 886-2-2712-0191

Seaward Electronics Incorporated – North America

1512 Centre Pointe Dr.

Milpitas, CA95035, USA

Tel: 1-408-821-6600

Last Updated - 12/11/2019